

RELAY ISOLATING THE ACCESSORY WIRE (1993-1997 NISSAN ALTIMAS)

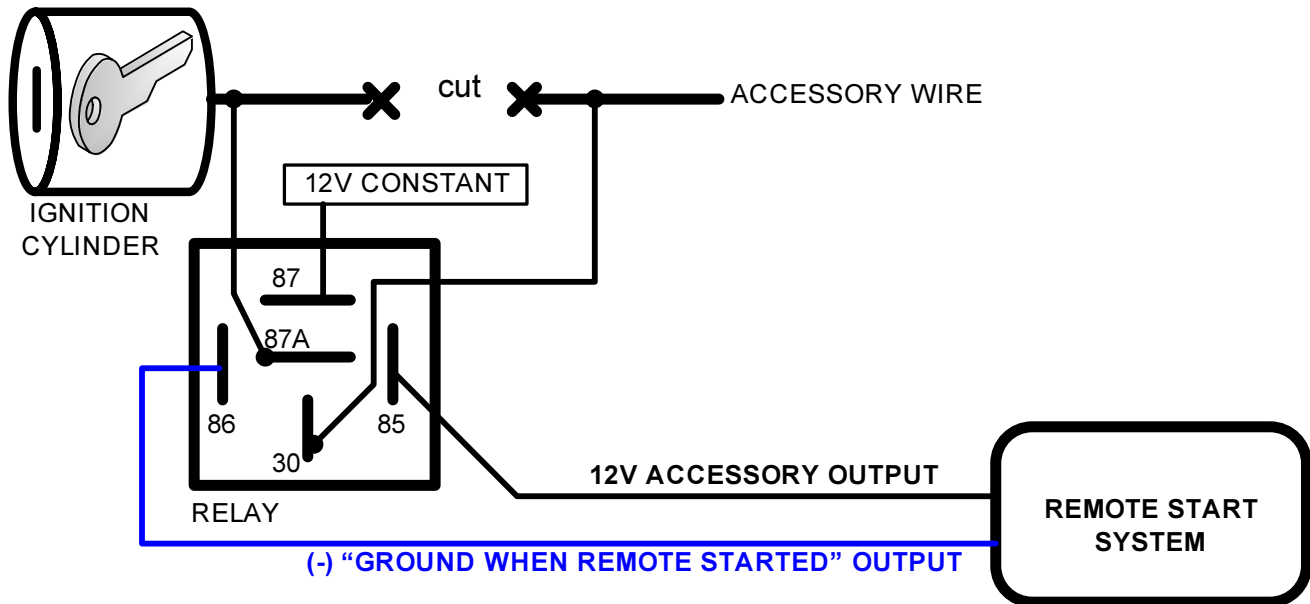

NOTE:

On 1993-1997 Nissan Altimas, when installing a remote start system, a relay must be used to isolate the accessory wire from the ignition key switch.



PIN	CONNECTION
85	TO 12V ACCESSORY OUTPUT FROM REMOTE START
86	TO (-) "GROUND WHEN REMOTE STARTED" OUTPUT FROM REMOTE START
87	TO 12V CONSTANT (25 AMP CAPABLE)
87A	TO KEY CYLINDER SIDE OF ACCESSORY WIRE
30	TO CAR SIDE OF ACCESSORY WIRE

Remote starter and security installations should be attempted by experienced security installers only. Information contained is accurate to the best of our knowledge and experience. Information contained is without any representation of warranty. It is the installer's responsibility to test and confirm all circuits with a digital multi-meter. Proper installation remains the responsibility of the installer. CarInstallExperts.com assumes no liability or responsibility resulting from an improper installation, even in reliance with the information contained in this guide.